



# **Analysis of Energy and Cost Performance of Retrofitting Fluorescent Tubes with Compact Fluorescent and Light Emitting Diode Lamps**

**J. S. Adeleke<sup>1\*</sup>, A. B. Wahab<sup>2</sup> and E. A. Olanipekun<sup>2</sup>**

<sup>1</sup>*Department of Building, Federal Polytechnic, Ede, Nigeria.*

<sup>2</sup>*Department of Building, Obafemi Awolowo University, Ile-Ife, Nigeria.*

## **Authors' contributions**

*All authors designed the study and performed the statistical analysis. Author JSA wrote the protocol, performed the experiment and wrote the first draft of the manuscript. Author ABW designed the methodology and analysed the data. While, author EAO chronicled the background to the study, wrote the abstract and managed the literature searches with author JSA. All authors read and approved the final manuscript.*

## **Article Information**

DOI: 10.9734/JERR/2020/v14i417133

### Editor(s):

(1) Dr. David Armando Contreras-Solorio, University of Zacatecas, Mexico.

### Reviewers:

(1) Velmani Ramasamy, India.

(2) S. R. Paraskar, Sant Gadge Baba University, India.

Complete Peer review History: <http://www.sdiarticle4.com/review-history/58541>

**Original Research Article**

**Received 07 May 2020**  
**Accepted 11 July 2020**  
**Published 28 July 2020**

## **ABSTRACT**

Over the years, visual comfort has been described as a major requirement needed to enhance optimal performance of occupants in any learning environment in tertiary institutions. This is reflected in the poor performance of the commonly used Fluorescent Lamps (FL) occasioned by its constant burn-off, high failure rate and reduced durability. Hence, there is a shift to the adoption of Compact Fluorescent Lamp (CFL) and Light Emitting Diode (LED). This study therefore examined the pattern of electricity consumption involving the adoption of FL, CFL and LED in the purposively selected lecture theatres of Obafemi Awolowo University, Ile-Ife, Nigeria. The study was carried out using energy monitor to obtain the consumption data of the lamps for periodic logging at intervals of 1 hr, 3 hrs, 6 hrs, 12 hrs, 1 day, 7 days, 1 month and 3 months respectively; and also to determine the payback period of each of the lamps. From the data collected, patterns of electricity used, electricity savings were calculated and compared to establish performance potentials of each of the lamps. The study found that there was a significant difference in the pattern of electricity consumption of FLs compared with that of CFLs and LEDs, but a reduced margin existed between

\*Corresponding author: Email: [adelekesholla@gmail.com](mailto:adelekesholla@gmail.com);

CFLs and LED lamps. It showed that the FLs consumed 681.576 kWh, 1619.466 kWh and 5652.432 kWh, CFLs consumed 387.302 kWh, 692.479 kWh and 1936.600 kWh, while LED consumed 294.188 kWh, 426.608 kWh and 1499.015 kWh. There were significant differences in consumption with 43, 47 and 65% reduction in electricity consumption using CFLs while 57, 73 and 73% using LED fittings were obtained. The CFLs performed better in terms of return on investments by having a lower payback period when compared to LED. The study concluded that replacing FL with CFL and LED would be desirable option in order to enhance optimal performance of lecture theatres, but in terms of payback period, it would be beneficial to retrofit FLs with CFLs.

*Keywords: Consumption; cost; energy; environment; learning; lighting types; performance; retrofitting.*

## 1. INTRODUCTION

Lighting is an important building component that contributes greatly to the quality of life of occupants and productivity of the workforce. Artificial illumination contributes significantly to the productive day, enabling people to work in home, school, office and factory buildings [1]. According to [2] lighting provides visual environment in classrooms that enhances learning process for both students and teachers. The provision of lighting in educational institution lecture halls contributes greatly to the academic performance of students in higher institutions. A lecture hall is a physically comfortable space within the campus that allows the students to learn through seeing and hearing the teaching material presented. Subsequently, educational institution lecture halls are recommended to have an illuminance level of 300-500lux but majority of them fell below minimum illuminance standards, which affects the reading and writing activity and sometimes further leads to impaired vision [3].

Pilot studies conducted on academic institution lecture halls of Obafemi Awolowo University Ile-Ife, revealed that majority of the academic lecture halls are characterized with regular failure of existing fluorescent lamps, due to low quality of fluorescent lamps available in the country. Poor finance and budgetary provision and inability of the institution to replace failed lamps regularly as at when due, had led to a low visibility level in these academic institution lecture halls. Consequently, low visibility and reduction in viewing capacity of the users. Many times users have to bring task lamps in order to see and listen to lectures. This has become worrisome to the Managers of the University Institution. Maintaining sufficient lighting levels is necessary for the productive operation of any institutional lecture hall [4].

However, Lighting need is important in energy analysis for two main reasons; artificial lighting

consumes a significant amount of energy and of course, it influences the heating and cooling loads by generating internal heat during its utilization thus bringing about the need to critically control lighting energy consumption in buildings [5]. However, a viable available option is retrofitting lighting system with energy efficient lamps, which is a recommended approach for enhancing energy efficacy of old in-efficient lighting fittings for education instructional lecture halls [6]. Lighting energy used in these buildings is substantial after Heating Ventilation and Air Conditioning (HVAC) energy use, lighting energy use in this buildings account for approximately 20% of the total and cost the university about 10 million naira [7]. Consequently, upon this the management is ever ready to retrofitting these lamps with more energy efficient, environmental friendly, low operation and low maintenance one. However, the institutional management is limited by performance of data on existing efficient lamps.

Lighting retrofits are actions that allows the upgrade of lighting energy and environmental performance to a higher standard than what was originally installed [8]. Lighting retrofit is the process of modifying existing lighting fixtures after it has been installed [9]. Retrofitting with energy efficient lighting deals primarily with technologies for realigning improvements in lamp electrical energy usage, thereby accomplishing a specified objective of using less energy [10]. Improving lighting efficiency increases the performance of energy sources by providing specified services with less energy resources. Similarly, improved energy efficient lighting technologies also have great potentials of saving electricity, reducing emission of greenhouse gases associated with electricity production and reducing consumers energy cost [10].

Among the existing efficient lamps, compact fluorescent lamps (CFLs) and light emitting diode (LEDs) are the common and probably the best

alternatives to fluorescent lamps due to its positive in energy savings, its suitability in changing from florescent tubes to CFLs and LED, durability, provides better light quality, reduced energy bills and provide a better indoor environmental quality [11]. However, the results obtained from previous research in lighting retrofits approach were based on theoretical approach, verification of actual field performance of the two commonly available energy saving lamps have not been carried out to establish if these theoretical estimation reflects the outcome of the field observations. It has already been revealed that field performance evaluation has a long history. For example, [12] found out that LEEDS certified buildings consume 18% to 39% less energy per floor area than their conventional counterpart on the average, which is based on the comparism of 100 LEEDS commercial and institutional buildings to the energy use of the American commercial buildings. Nevertheless, 28% to 35% of LEEDS certified buildings are using more energy than their conventional counterparts. Of the LEEDS-certified, 25% cannot save as much energy as predicted in the design process [13]. [14] has pointed out that the construction method of GBs is not mature enough and the use of new GB technologies may cause potential risk. The building performance gap between design prediction and actual consumption is the beginning of building performance evaluation. Studies have also shown that improvement based on theoretical performance data are often at variance to the field performance due to several factors. Consequently, studies were undertaken worldwide to verify the acclaimed theoretical performance. In line with this thought, the current research aims to provide field performance data using energy monitor for the two commonly available energy saving lamps. This was carried out to provide useful information to the management of Obafemi Awolowo University in decision-making process towards sustainable energy.

## **2. LITERATURE REVIEW**

### **2.1 Importance of Lighting Scheme in Building Energy Use and Lighting Retrofitting**

Lighting is an important part of any educational institution energy load and hence, it plays a very important role in increasing profit margin by energy conservation approach [15]. Artificial lighting is dependent on electricity and has the

highest CO<sub>2</sub> emission factor of energy sources at 0.422 kgCO<sub>2</sub>/kWh, which further emphasizes the need for reducing energy used for illuminating buildings [15]. Therefore, the management of energy usage by lighting schemes in buildings is gaining more attention in recent years. Illumination improvement is an excellent investment in most of the institutional buildings where 70% to 80% of electricity bills are affected by electrical bulbs [16]. Energy efficient lighting retrofitting technology provides the opportunity to implement cost effective saving measures without a substantial modification in the existing design.

Lighting Retrofit is the process of replacing existing lighting fixtures to improve lighting output, temperature and lighting energy use in buildings [17]. These energy savings are realized over time and can be significant enough, not only to pay for new equipment, but produces a return on the investment [18]. [19] pointed out that investment in energy efficient lighting is one of the most cost-effective ways for improving energy efficiency in buildings and reduce CO<sub>2</sub> emissions. According to [20] energy retrofits of lighting equipment are very cost-effective with typical payback periods of less than two years. In addition, higher costs of electricity compared to most other energy sources (e.g. natural gas) in most countries further justifies ranking lighting retrofit measures high on the list of options as suggested by [21].

### **2.2 Performance Characteristics of CFL and LED Lighting Technologies**

Energy efficient lamps have been designed to deliver illumination with similar characteristics to incandescent lamps and fluorescent tubes. The CFLs and LED offers a better characteristics when compared to fluorescent and incandescent lamps, which made it more suitable for artificial lighting in buildings that includes:

#### **2.2.1 Spectrum of light**

CFLs emit light from a mix of phosphors inside the bulb and each emits one band of colour. Modern phosphor designs balance the emitted light colour, energy efficiency and cost. Every extra phosphor added to the coating mix improves colour rendering but decreases efficiency and increases cost. Good quality consumer CFLs use three or phosphors to achieve a "white" light with a colour rendering index (CRI) of about 80, where the maximum 100 represents the appearance of colour under

daylight or a black-body depending on the correlated colour temperature.

### 2.2.2 Energy efficacy

The eye's sensitivity changes with the wavelength; the output of lamps is commonly measured in lumens, a measure of the power of light as perceived by the human eye. The luminous efficacy of lamps is the number of lumens produced for each watt of electrical power used. The luminous efficacy of a typical CFL is 50–70 lumens per watt (lm/W). [22] Compared to a theoretical 100% efficient lamp (680 lm/W), CFL lamps have lighting efficiency ranges of 7–10%, versus 1.5–2.5% for incandescent. Due to the higher efficiency, CFLs use between one-seventh and one-third of the power of equivalent incandescent lamps [23], also admitted that CFLs use much less energy than incandescent lamps (ILs) as a phase-out of ILs would result in less carbon dioxide (CO<sub>2</sub>) being emitted into the atmosphere. Exchanging ILs for efficient CFLs on a global scale is expected to achieve annual CO<sub>2</sub> reductions of 230Mt (million tons).

### 2.2.3 Cost

While the purchase price of a CFL is typically 3–10 times greater than that of an equivalent incandescent lamp, a CFL lasts 8–15 times longer and uses two-thirds to three-quarters less energy. [30] opined that a household that invested \$90 in changing 30 fixtures to CFLs would save \$440 to \$1,500 over the five-year life of the bulbs, depending on the cost of electricity. The utility bill of 12% discount is estimated as the savings. CFLs are extremely cost-effective in commercial buildings when used to replace incandescent lamps. [24] however, admits that frequent on-off cycling turning on and off (CFLs) greatly reduces their lifespan. CFLs should be avoided in places where lights are frequently turned on and off, as it would increase costs and add to e-waste generation.

### 2.2.4 Dimming

Only some compact fluorescent lamps are labeled for dimming control. Using a dimmer with a standard CFL is ineffective and can shorten bulb life and void the warranty. The dimmer switch used in conjunction with a dimmable CFL must be matched to its power consumption range. CFL applications commonly draw power in the range 7–20 W. Dimmable CFLs have been marketed before suitable dimmers are available. The dimming range of CFLs is usually between

20% and 90%, but many modern CFLs have a dimmable range of 2% to 100%, more akin to that of incandescent lights. There are two types of dimmable CFL on the market: Standard dimmable CFLs, and "switch-dimmable" CFLs [25]. Dimmable CFLs are more expensive than standard CFLs due to the additional circuitry. Cold-cathode CFLs can be dimmed to low levels, making them popular replacements for incandescent bulbs on dimmer circuits. When a CFL is dimmed, its colour temperature (warmth) stays the same.

### 2.2.5 Colour rendering index

The colour rendering index is a measure of how accurately light from a source will reproduce colours. The CRI are major factors used by manufacturers' to promote their lighting products. These technical terms help understand issues related to light quality offered by lighting bulbs. The colour produced by LED and CFLs are superior to older technology. They are ideal lighting source for applications in school, factories and warehouses.

### 2.2.6 Temperature

Temperature plays a major role in the performance of lighting system. The cooler the environment, the more lumens or light the LED will produce; therefore, controlling the temperature of building space will help to minimize the efficiency of the LED lighting system. In overall, LEDs light output is affected by the temperature of the environment they are installed. In high temperature, facilities may have slight decrease in the light output.

## 2.3 Monitoring and Evaluation of Potential Energy Savings in Lighting Retrofits

Several devices and instruments can be used to measure and monitor the amount of energy consumption and hence, potential energy savings for lighting retrofits measures or action this can be achieved by:

### 2.3.1 Digital and analog meter

Electricity meter, electrical meter and energy meter is a device that measures the amount of electric energy consumed by a residence or electrical power device. Electric utilities uses electric meters installed at consumers premises for billing purposes. They are typically calibrated in billing units and the most common one being the kilowatt hour (kWh). Electricity meters

operate by continuously measuring instantaneous voltage (volts) and current (amperes) to give energy used over a period of time in joules kilowatt- hours [26].

### 2.3.2 Smart grid meter

Measures and read the consumption of electricity remotely using a smart meter and communicate network. It provides the real time or near real time information on the consumption of electricity to utility companies or service companies. The smart metering system for homes focused on measuring the total amount of energy consumption or electricity at a home and communicate infrastructure for data transaction. It could measure or monitor the electricity consumption of each home appliance, better intelligent services could be provided such as tracking energy consumption, statistical analysis, and rule-based configuration. In the home network area, the data of energy consumption from each home appliance are collected using sensor networks [26]. However, more recently was the use of energy monitor coupled with microcomputer interface in the monitoring of energy consumption for lighting, which offers a better advantage in the control, and evaluation of energy through a computer based programme.

### 2.3.3 Energy monitor

Energy monitor offers a promising solution for the measurement of the energy used by appliances when connected to the house mains and it measures the direction of power flow. They are used for appliances with resistive loads such as (lighting bulbs, kettles, electric water heaters) which means that their current draw is equal to the voltage divided by their resistance (Ohms law). The hardware consists of a non-invasive current sensor, alternatively called current transformer (CT), which uses an YHDC SCT-013-000 split core clipped-on current transformer, a voltage sensor alternatively called voltage transformer (VT). It uses a single-phase supply either with Mascot AC as required by BS.1363 (13A) socket outlet, a microcontroller unit (MCU), memory storage, lead indicator and a Zig-Bee module. The current/voltage measuring circuit measures the current, voltage and sends the information to the MCU. The MCU checks for power abnormalities and sends information to the microcomputer, where a database is maintained through Zig-Bee. A graphic user interface (GUI) software program is used as an interface between the user and the

end devices. Subsequently, the user can control all electrical data through a micro-computer [27].

## 3. METHODOLOGY

This research work adopts quantitative approach by carrying out simulation of as-built set-up of the selected lecture halls of Obafemi Awolowo University, Ile-Ife using field device. A purposive sampling techniques was utilized, due to the heterogeneous nature of the sampling size of identified lecture halls in Obafemi Awolowo University Ile-Ife. Three lecture halls were selected based on physical characteristics, which includes, size of the lecture hall in (m<sup>2</sup>) and their seating capacity were used as basis for design typology in the sampling process. A single-phase connection was utilized which included live cable and a neutral. A clear identification of the live and neutral cable was done on the electricity supply consumer control unit (CCU) prior to the installation of the energy monitor. The energy monitor was then connected to the set-up like a normal appliance using the Zig-Bee module graphic user interface (GUI) software program, which monitor, evaluates and processed energy consumption data through the micro-computer that was connected to the set-up as shown in Figs. 1-5. Indoor Environmental Qualities were carried out before, during and after the experiment in the morning, afternoon and evening time using voltmeter, thermometer and hygrometer to measure voltage drop in the set-up, internal temperature and relative humidity of the laboratory environment in order to provide background information on the indoor environmental qualities. The energy data was uploaded online from a wireless module microcomputer at intervals of (1 hr, 3 hrs, 6 hrs, 12 hrs, 24 hrs, 7 days, 1 month and 3 months) from the as-built simulated fluorescent lamps (FLs), compact fluorescent lamps (CFLs) and light emitting diode (LED) respectively.



**Fig. 1. Arrangement of as-built lamps for pre-retrofits data collection**

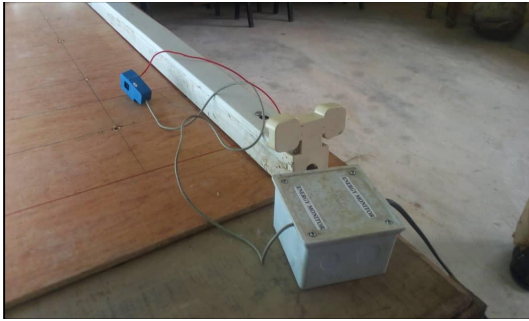

**Fig. 2. Connection of Energy Monitor to the lighting load**



**Fig. 3. Pre-retrofits data collection process**



**Fig. 4. Post retrofits data collection from 26W CFLs**



**Fig. 5. Pre-retrofits & Post-retrofits online data collection from the as-built lamps**

## 4. RESULTS AND DISCUSSION

### 4.1 Investigation on the Indoor Environmental Qualities

Fig. 7 shows the investigation of the indoor environmental qualities (IEQ) in regards to the internal environment of the experiment carried out in the laboratory. It was revealed that the average voltage dropped in the set-up was between 213-215V throughout the period of the experiment. The average voltage drop in the set-up in the morning time before the experiment was an average of 214V and was later decreased to 210.5V during afternoon hour. The decrease in the voltage dropped was attributed to high electricity usage by electrical appliances and the resistance to the flow of electric current in the circuit heating up the electrical cables thereby reducing the voltage drop in the set-up. Subsequently, at evening hours the average voltage drop in the set-up increased to an average voltage of 215V due to the low temperature of the internal environment and less energy usage by appliances within this period. In addition, the average temperature of the internal environment varied between the ranges of 29-32.5°C. The average internal temperature at 29°C in the morning increased to average 32.5°C in the afternoon time and later reduced to average temperature of 30.1°C. This was due to the heat discharged/emitted from the lamps during the afternoon hour and the heat gained from external environment into the building and the set-up. Similarly, the average humidity level varied between the ranges of 65–61.5% in the laboratory within morning and evening period. The humidity level with 65% in the morning decreased to 61.5% in the afternoon. This was also due to the heat discharged from the lamps set-up and the heat gained from external environment, which reduced the amount of humidity available in the laboratory environment. At evening period, the humidity level increased to 64.2%. Furthermore, the rate of heat emission was very high with fluorescent lamps and lesser with CFLs and LED lamps during the three month of the experiment. Subsequently, energy consumption increased significantly during the morning and evening time for the three Lamps. The result of the experimental investigation carried out clearly revealed that temperature and humidity and voltage drop has direct influence on the energy consumption performance of lamp fixtures. Furthermore, colour rendering index CRI also revealed that the colour quality of light produced by LED and CFLs are superior to the florescent lamps in the set-up.

#### 4.2 Comparative Analysis of Energy Consumption Pattern of Existing FLs, CFLs and LED lamps in ALT, ODLT and Moremi Lecture Halls in OAU

Figs. 8, 9 and 10 respectively also shows the comparative pattern of lighting energy consumption for the existing 36W Fluorescent lamps, 26W Compact fluorescent lamps and 18W light emitting diode lamps in ALT, ODLT and 1000 SLT Seater Lecture Halls. In ALT lecture hall having 16 numbers of as-built FLs, the lighting energy consumption increased from 7.404 kWh in 1 day to 229.096 kWh in 1 month and 681.576 kWh in 3 months. Retrofitting with CFLs and LED lamps the energy consumption also increased from 4.303 Wh, 3.313 kWh in 1 day to 129.101 kWh, 96.396 kWh in 1 month, and 387.302 kWh, 294.88 kWh in 3 months. While, in ODLT with 30 numbers 36W FLs, the energy consumption also increased considerably from 18.994 kWh in 1 day to 531.130 kWh in 1 month and 1619.4600 kWh in 3 months. Retrofitting with CFLs and LED the energy consumption also increased from 7.907 kWh, 5.265 kWh in 1 day to 216.243 kWh, 142.536 kWh in 1 month and 692.479 kWh, 426.608 kw in 3 months. Similarly, the 1000 SLT seater capacity lecture hall with 69 numbers 36W of as-built fluorescent lamps, the energy consumption also increased considerable from 60.028 kWk in 1 day to 1840.846 kWh in 1 month and 5652.4321 kWh in the 3 months. Retrofitting with CFLs and LED lamps the energy consumption also increased from 22.842 kWh, 17.050 kWh in 1 day to 657.243 kWh, 500.167 kWh in 1 month and 1936.600 kWh, 1499.015 kWh in 3 months of the experiments. The figures revealed that there exist a similar perfect (C) curve shape pattern of energy consumption for the FLs, CFLs and LED lamps across the three-selected simulated lecture halls. In the early stage of the experiment between the periods of 1-24 hours, the variance between the values observed were less significant in the pattern among the three lamps. However, there exist a higher level of significance different in the energy consumption pattern from 7 days-1 month. It was also revealed that a very high level of significance difference exist between the periods of 1-3 months respectively. Similarly, the figures revealed that lighting energy consumption is more significant when considering longer periods. For instance, In ALT, the values of the energy consumption decreased from 229.096 kWh to 129.101 kWh and 96.396 kWh in 1 month and 681.576 kWh to 387.302 kWh and 274.188

kWh in 3 months when retrofitting FLs with CFLs and LED lamps respectively. Likewise in ODLT, the values of energy consumption decreased from 531.130 kWh to 216.243 kWh and 142.536 kWh in 1 month and 1619.466 kWh to 692.479 kWh and 426.608 kWh in 3 months when retrofitting FLs with CFLs and LEDs lamps. Also, in the 1000 SLT seating lecture hall the energy consumption decreased from 1840.846 kWh to 657.243 kWh and 500.167 kWh in 1 month and 5652.432 kWh to 1936.600 kWh and 1499.015 kWh when retrofitting FLs with CFLs and LED lamps respectively. The figures further revealed that there exist wide margin between the energy consumption of existing FLs with that CFLs and LEDs but a very small margin between CFLs and LED lamps within this period, which ascertained the facts that the studies from literatures that the two lamps examined were truly energy saving lamps.

#### 4.3 Impact of Retrofitting Lighting using Compact Fluorescent Lamps (CFLs) and Light Emitting Diode Lamps (LED) in the Simulated Lecture Halls

This section shows the pearsons' correlation analysis between the existing fluorescent lamps (FL), compact fluorescent (CFLs) and light emitting diode (LED) lamps for the three selected simulated lecture halls in the study area. Table 1, 2 and 3 shows the correlation values for the simulated ALT I, ODLT and 1000 SLT Seater Capacity lecture hall to be 1.000 which indicates a very strong positive correlation. It also shows that the more time the experiment/onsite data collection takes place its effects on energy consumption was very high. The 2-tailed significant value was observed to be 0.000 less than the standard alpha value of 0.05, which means that the correlation is highly significant.

#### 4.4 Percentage Energy Savings for Compact Fluorescent Lamps and Light Emitting Diode Lamps

Similarly, Fig. 12 further shows that, the test carried out on percentage energy savings in ALT simulated lecture halls, which revealed that there were significant differences between the energy consumption before and after installations of CFLs and LED lamps. Moreover, about 43% reduction in electricity consumption were achieved using compact fluorescent lamps, which is in line with research carried out by [28] and 57% for light emitting diode fittings. Similarly, test results carried out on percentage energy

savings in ODLT lecture hall also revealed that there were significant differences between the energy consumption before and after installations of CFLs and LED lamps. Moreover, about 47% reduction in electricity consumption were achieved using compact fluorescent lamps, which is also in line with research carried out by [28] and 73% for light emitting diode fittings. Also, the test results carried out on percentage energy savings for Moremi halls also revealed that there were significant differences between the energy consumption before and after installations of CFLs and LED. In addition, about 65% reduction in electricity consumption were achieved using compact fluorescent lamps, which is in line with the research carried out by [29] and 73% for light emitting diode fittings.

#### 4.5 Payback Period of the Investment made on Lighting Retrofitting using Compact Fluorescent Lamps and Light Emitting Diode Lamps

The payback period was determined using a simple payback equation:

$$P_T = \frac{IC}{AS} \tag{1}$$

Where,

$P_T$  = Payback period,  
 IC = Cost of installing energy saving lamps,  
 AS = Total annual savings estimated.

Fig. 12 shows the results of the payback period of the retrofitting action which revealed that the compact fluorescent lamps performed better in return of lighting retrofits investments with payback period of 7 years, 4 years and 5 years respectively for small, medium and the large simulated lecture halls respectively. While, that of the light emitting diode lamp has a higher payback period of 10 years, 6 years and 8 years respectively for the small, medium and large halls respectively. The outcome of the payback period also revealed that the CFLs have a better return of investment when compared to LED lamps. This implies that in 7 years, 4 years and 5 years respectively for the small, medium and large halls the University would have made back its initial investment on the purchase and installations of the energy efficient lighting installations.

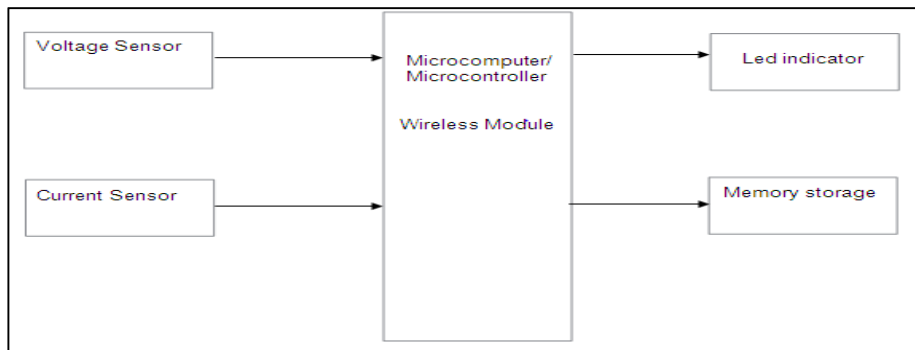

Fig. 6. Block diagram of the energy monitor

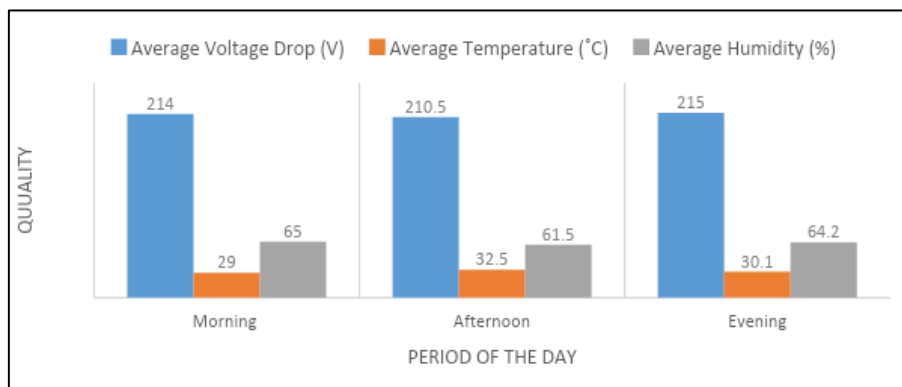
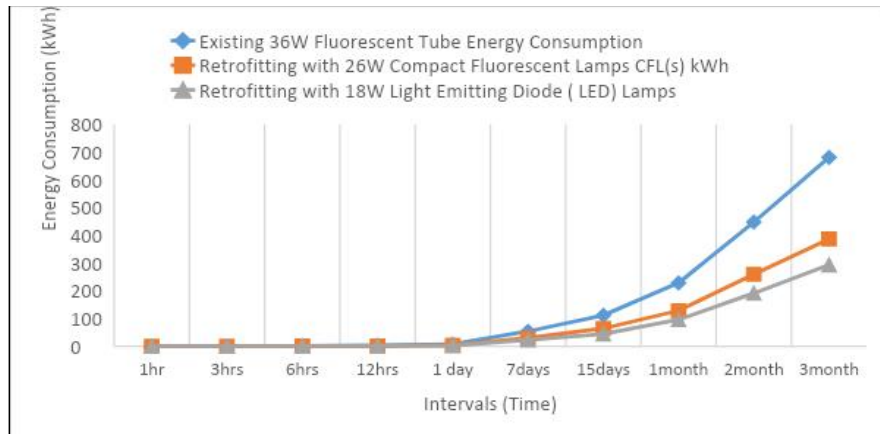
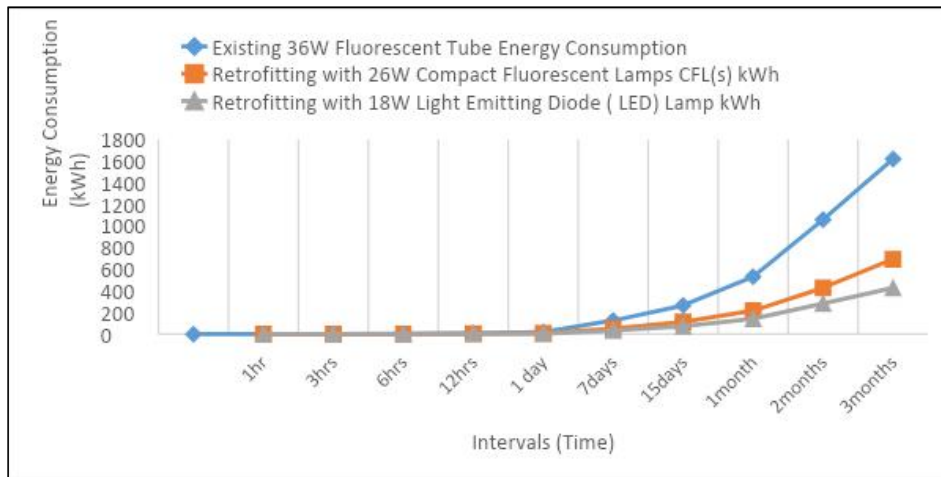

Fig. 7. Characteristics of the indoor environmental qualities

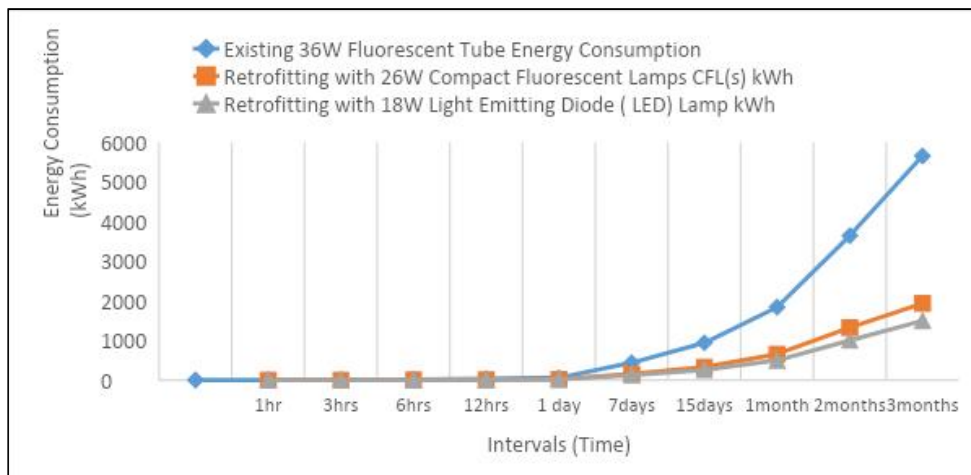



**Fig. 8. Analysis of energy consumption pattern of the existing FLs, CFLs and LED lamps for ALT lecture hall**



**Fig. 9. Analysis of energy consumption pattern of the existing FLs, CFLs and LED Lamps for ODLT Lecture Halls**



**Fig. 10. Analysis of energy consumption pattern of the existing FLs, CFLs and LED lamps for Moremi lecture hall**

**Table 1. Correlation analysis for the simulated ALT lecture halls**

		EFL	RCFL	RLED
EF	Pearson Correlation	1	1.000**	1.000**
TC	Sig. (2-tailed)		.000	.000
	N	9	9	9
RC	Pearson Correlation	1.000**	1	1.000**
FL	Sig. (2-tailed)	.000		.000
	N	9	9	9
RL	Pearson Correlation	1.000**	1.000**	1
ED	Sig. (2-tailed)	.000	.000	
	N	9	9	9

\*\* Correlation is significant at the 0.01 level (2-tailed)

**Table 2. Correlations analysis for the simulated ODLT I and II lecture halls**

		EFL	RCFL	RLED
EFTC	Pearson Correlation	1	1.000**	1.000**
	Sig. (2-tailed)		.000	.000
	N	9	9	9
RCFL	Pearson Correlation	1.000**	1	1.000**
	Sig. (2-tailed)	.000		.000
	N	9	9	9
RLED	Pearson Correlation	1.000**	1.000**	1
	Sig. (2-tailed)	.000	.000	
	N	9	9	9

\*\* Correlation is significant at the 0.01 level (2-tailed)

**Table 3. Correlation analysis for the simulated 1000 Seater Moremi lecture hall**

		EFL	RCFL	RLED
EF	Pearson Correlation	1	1.000**	1.000**
TC	Sig. (2-tailed)		.000	.000
	N	9	9	9
RC	Pearson Correlation	1.000**	1	1.000**
FL	Sig. (2-tailed)	.000		.000
	N	9	9	9
RL	Pearson Correlation	1.000**	1.000**	1
ED	Sig. (2-tailed)	.000	.000	
	N	9	9	9

\*\* Correlation is significant at the 0.01 level (2-tailed)

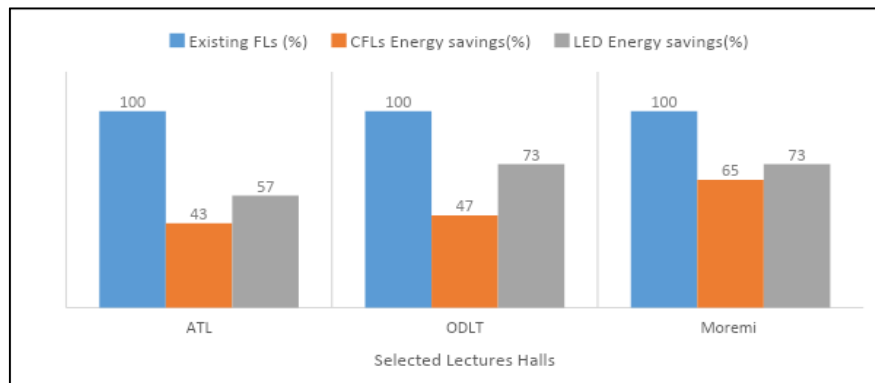

**Fig. 11. Percentage energy savings of compact fluorescent lamps and light emitting diode lamps**

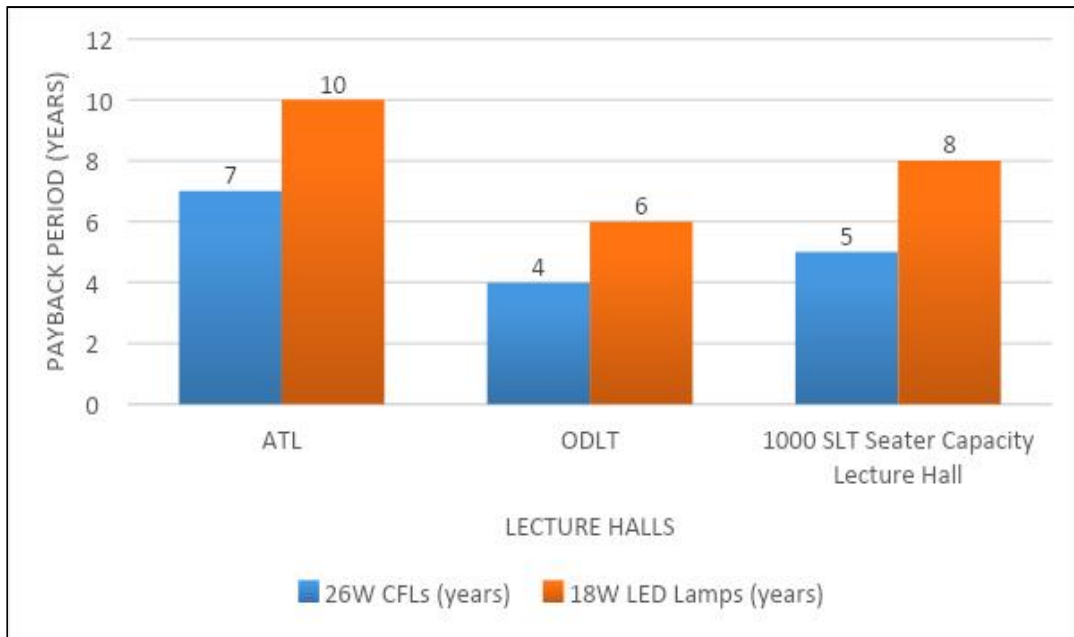

**Fig. 12. Payback period of lighting retrofits investment for ATL, ODLT and Moremi lecture halls in OAU**

## 5. CONCLUSION

The study concluded the pattern of lighting energy consumption increased significantly and was consistent as the time under consideration increased and the trend of the energy consumption shows a perfect (C) curve across the three-selected lecture halls in kWh. The results further revealed that there exist wide margin between the energy consumption of existing FLs with that CFLs and LEDs but a very small margin between CFLs and LED lamps within this period. It also revealed that the more time data collection takes place its effects on energy consumption was very high having a significant percentage of energy savings.

The following recommendations are made from this study

- The study recommends that lighting retrofits have tendencies to save energy over a long period most especially for lecture halls having significant numbers of lighting stocks.
- The payback period of investment of 1-10 yrs of the two energy savings lamps was observed to be very high which was as a result of the high cost of purchase and manufacturing and importation of the

lamps. The government should provide incentive scheme on the manufacturing and importation of CFLs and LED since they have tendencies to reduce energy consumption in households.

- The present study focused on simulation of the selected lecture halls in the study area, further study could focused on actual field measurements of the as-built lamps in the selected study area.

The present study looks at two major energy saving lamps, which includes the CFLs and LEDs without considering varieties of brands and products. Further studies could also look into varieties of brands and products of energy saving lamps and its effects on energy consumption.

## COMPETING INTERESTS

Authors have declared that no competing interests exist.

## REFERENCES

1. United Nations Environment Programme (UNEP), Handbook for Drafting Laws on Energy Efficiency and Renewable Energy Resources; 2007.

2. Illuminating Engineering Society of North America (IESNA) Lighting Handbook, 2000.
3. Rashid MSB. Physiological reaction to light: The understanding of lighting design through health and visual safety. Makalah disajikan dalam The 6th International Seminar on Sustainable Environment and Architecture, Department of Architecture, Institute Technology Bandung, Bandung; 2002.
4. Ryckaert WR, Lootens C, Geldof J, Hanselaer P. Criteria for energy efficient lighting in buildings. *Energy and Buildings*. 2010;42(3):341-347.
5. United State Environmental Protection Agency, Report on Energy Policies and Issues; 2012.
6. Grinfeld F, Grinfeld U, Washington DC, US Patent No. 8,022,634. U.S. Patent and Trademark Office; 2009.
7. Jaggs M, Palmer J. Energy performance indoor environmental quality retrofit – A European diagnosis and decision-making method for building refurbishment. *Energy and Buildings*. 2000;31(2):97–101.
8. City of Melbourne, What is a Building Retrofit? City of Melbourne; 2013.
9. Europa U, DIRECTIV 2012/28/UE DEL PARLAMENTO EUROPEO Y DEL CONSEJO de 25 de octubre de 2012 sobre ciertos usos autorizados de las obras huérfanas.
10. Arvind D, Tejinder S. Energy conservation with energy efficient lighting. *Environment and Development*. 2009;(10)5:630-639.
11. Newsham GR, Mancini S, Birt BJ. 'Do LEED-Certified building save energy? Yes, but *Energy and Buildings*. 2009;41(8):897-905.
12. Holbrook J, Rannikmae M. The meaning of scientific literacy. *International Journal of Environmental and Science Education*. 2009;4(3):275-288.
13. U.S Council of Green Building, Sustainable Building Technical Manual: Green Building Design, Construction and Operations; 1996.
14. Shanker R. Energy auditing in electrical utilities. Viva-books; 2010.
15. Lee Y, Guerin DA. Indoor environmental quality difference between office types in LEED- Certified buildings in the US. *Journal of Building and Environment*. 2010;45(5):1104-1112.
16. Khalifa SA, Saleh A. Energy-efficient envelope design for residential buildings: A case study in Oman. *Smart Building Symposium Prague*. 2017;1-8.
17. White Lighting System, White Lighting. *Colour Research and Application*. 2018;38(2):82-92.
18. Lighting Search, Lighting Retrofits Economics. Digitalize your light. Lightsearch.com; 2017.
19. Enkvist P, Nauclér T, Rosander JA. Cost curve for greenhouse gas reduction. *McKinsey Quarterly*. 2007;1:34.
20. Krarti M, Erickson PM, Hillman TC. A simplified method to estimate energy savings of artificial lighting use from day lighting. *Build. Environ*. 2005;40:747-754. DOI: 10.1016
21. Boyano A, Nandez P, Wolf O. Energy demands and potential savings in European office buildings: Case studies based on energy plus simulations. *Energy and Buildings*. 2013;65:19-28.
22. U.S Department of Energy, Building energy Software Tools Directory; 2013. Available:[http://apps1.eere.energy.gov/buildings/toolsdirectory/alpha\\_list.cfm](http://apps1.eere.energy.gov/buildings/toolsdirectory/alpha_list.cfm)
23. Enlighten, United Nations Environment Programme. United State of America; 2010.
24. Chernoff H. The cost-effectiveness of compact fluorescents in commercial buildings. Energy saving light bulbs offer dim future. The 2009 National Electrical Manufacturer's Association NEMA, Failure Modes for Self-Ballasted Compact Fluorescent Lamps; 2008.
25. Yau EKF, Ki. Wing-Hung, Mok PKT, Sin JKO. Phase-Controlled Dimmable CFL with PFC and Switching Frequency Modulation. *IEEE 32<sup>nd</sup> Annual Power Electronics Specialists Conference (IEEE Cat. No.01CH37230)*. 2001;2:951-956. IEEE.
26. Hammond PA, Ali D, Cumming DR. A system-on-chip digital pH meter for use in a wireless diagnosis capsule. *IEEE Transaction on Biomedical Engineering*. 2005;52(4):687-694.
27. Javiad N, Sharif A, Mohmood A, Ahmed S, Qasim U, Khan ZA. Monitoring and controlling power using zigbee communication. 7<sup>th</sup> IEEE International Conference on Broadband, Wireless

- Computing, and Applications. 2012;608-613.
28. Sule BF, Ajao KR, Ajimotokan HA, Garba MK. Compact fluorescent lamps and electricity consumption trend in residential buildings in Ilorin. International Journal Energy Sector Management. 2011;5(2):30.
- Hourglass. A united State of American Article. 2009;50(19):162-168.
29. CREDC; 2009.

---

© 2020 Adeleke et al.; This is an Open Access article distributed under the terms of the Creative Commons Attribution License (<http://creativecommons.org/licenses/by/4.0>), which permits unrestricted use, distribution, and reproduction in any medium, provided the original work is properly cited.

*Peer-review history:*

*The peer review history for this paper can be accessed here:*  
<http://www.sdiarticle4.com/review-history/58541>